

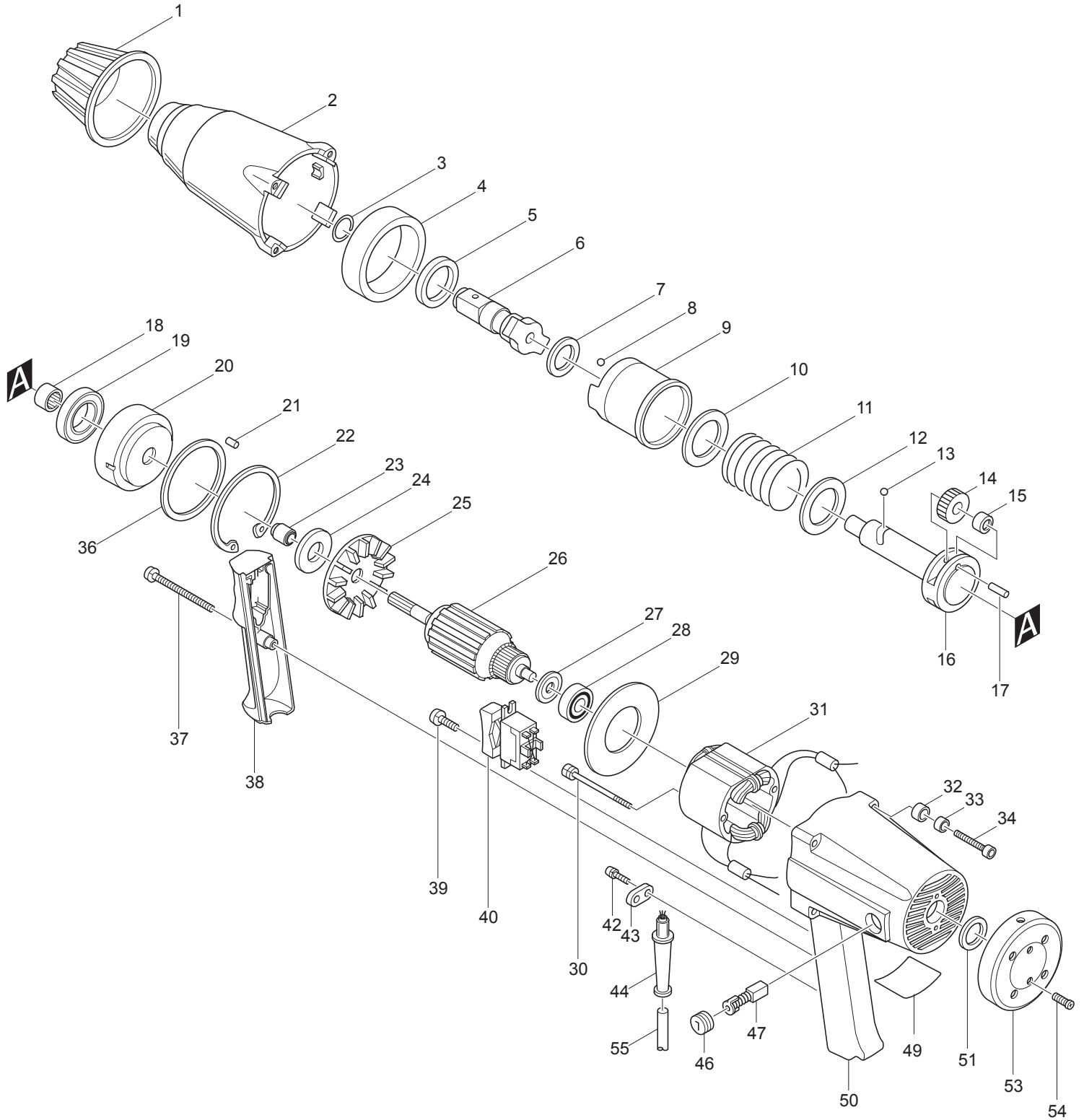

02 - 2010

6906

3/4" IMPACT WRENCH



Item	Type	Sub	Part No.	Description	Qty	Unit
001			421112-0	BUMPER	1	PC.
002			156087-1	HAMMER CASE	1	PC.
		INC.	213360-3	OIL SEAL 25	1	PC.
		INC.	257535-4	SLEEVE 25	1	PC.
003			231920-9	* RING SPRING 16	1	PC.
004			257040-1	RING 65	1	PC.
005			253939-8	FLAT WASHER 25	1	PC.
006	2		134946-9	* ANVIL ASS'Y	1	PC.
		INC.		Item No. 3		
007			261023-5	WASHER 27	1	PC.
008			216008-6	STEEL BALL 4	30	PC.
009			325318-1	HAMMER	1	PC.
010			253764-7	* FLAT WASHER 30	1	PC.
011			231135-8	COMPRESSION SPRING 37	1	PC.
012			253765-5	* FLAT WASHER 36	1	PC.
013			216009-4	STEEL BALL 7.1	2	PC.
014			221243-3	SPUR GEAR 29	2	PC.
015			212011-5	NEEDLE BEARING 609	2	PC.
016			325322-0	SPINDLE	1	PC.
017			256041-6	PIN 6	2	PC.
018			212151-9	NEEDLE BEARING 1412	1	PC.
019			211441-7	BALL BEARING 3009	1	PC.
020			221242-5A	* INTERNAL GEAR 65	1	PC.
021			256040-8	PIN 5	4	PC.
022			962352-6	RETAINING RING R-75	1	PC.
023			216103-2	INNER SLEEVE 1016	1	PC.
024			253180-3	FLAT WASHER 10	1	PC.
025			241609-1	FAN 73	1	PC.
026			512881-5	ARMATURE ASS'Y 115V (OLD#612362-0 - N/L/A)	1	PC.
		INC.		Item No. 23-28		
027			681613-2	INSULATION WASHER	1	PC.
028			211031-6	BALL BEARING 608LLB	1	PC.
029			413008-9	BAFFLE PLATE	1	PC.
030			265350-2	+ HEX. BOLT M5X70	2	PC.
031			622282-0	FIELD 115V	1	PC.
032			253929-1	CUP WASHER 5	4	PC.
033			262001-8	URETHANE RING 5	4	PC.
034			922262-9	HEX. SOCKET HEAD BOLT M5X40	4	PC.
035			253303-3	THIN WASER 40 (OLD) - N/L/A	1	PC.
036			253774-4	* FLAT WASHER 65 (Added)	1	PC.
037			911173-3	PAN HEAD SCREW M4X45	1	PC.
038			414959-9	* HANDLE COVER	1	PC.
039			911106-8	PAN HEAD SCREW M4X8	1	PC.
040			651564-3	SWITCH SL220SD-4	1	PC.
042	2		911133-5	PAN HEAD SCREW M4X18	2	PC.
043			687002-9	STRAIN RELIEF	1	PC.
044			682503-2	* CORD GUARD 8-90	1	PC.
046			643600-9	BRUSH HOLDER CAP 6-10	2	PC.
047	2		194982-7	CARBON BRUSH CB-124 2PC/SET (W/ ORIGIN)	1	SET
048			953106-2	RIVET 0-5 (OLD)	4	PC.
049			815088-5	NAME PLATE F/6906	1	PC.
050			159414-1	* MOTOR HOUSING	1	PC.

Item	Type	Sub	Part No.	Description	Qty	Unit
		INC.	643603-3	BRUSH HOLDER 6-10	2	PC.
051			262010-7	URETHANE RING 18	1	PC.
052			253314-8	WASHER (OLD)	1	PC.
053			284065-2	* REAR COVER	1	PC.
054			922221-3	* HEX. SOCKET HEAD BOLT M5X16	2	PC.
055			664064-4	CORD W/PLUG 2P-18-2.5M, SJ	1	PC.
059			913206-0	SET SCREW M5X8 (OLD)	2	PC.
060			325365-2	* PIN 7 (OLD) - N/L/A	1	PC.
061			231157-8	* COMPRESSION SPRING 2 (OLD)	1	PC.
062			256710-9	* PIN 2 (OLD) - N/L/A	1	PC.
063			931102-0	HEX NUT M4 (F/MOTOR HSG) (OLD)	1	PC.
064			819064-1	MAKITA MARK	1	PC.
100			654037-5	INSLTED TERMINAL FK1.25-M3	4	PC.
102			652008-6	P.H. SCREW M3.5 X 7	4	PC.
103			654509-0	CLOSED END TERMINAL 2-SD (OLD)	2	PC.
104			654531-7	TERMINAL BLOCK 2P	1	PC.
105			819064-1	MAKITA MARK	1	PC.
106			654019-7	GARTER SPRING	2	PC.
107			654502-4	CONNECTOR P-2	2	PC.
400			273474-0	GRIP 37 (OLD# 273445-7 - N/L/A)	1	PC.
401			312700-3	GRIP BASE	1	PC.
402			345086-0	BELT	1	PC.
403			251920-3	CAP SQUARE NECK BOLT M6X30	1	PC.
D01			654037-5	INSLTED TERMINAL FK1.25-M3	4	PC.
D02			652008-6	P.H. SCREW M3.5 X 7	4	PC.
D03			654509-0	CLOSED END TERMINAL 2-SD (OLD)	2	PC.
D04			654531-7	TERMINAL BLOCK 2P	1	PC.
C01			826216-7	CARTON F/6906	1	PC.
<u>ACCESSORIES</u>			- See catalogue or visit www.makita.ca for more optional accessories -			
A01			122464-9	GRIP ASS'Y	1	PC.
		INC.		Item No. 400-403		
A02			182604-1	STEEL CARRYING CASE	1	PC.
		INC.	819143-5	MAKITA LABEL	1	PC.
A04	1		134869-1	EXTENSION BAR 19 ASSY	1	PC.
	2		134997-2	EXTENSION BAR 3/4" ASSY	1	PC.
A05	1		134876-4	UNIVERSAL JOINT 3/4"	1	PC.
	2		134998-0	UNIVERSAL JOINT 3/4"	1	PC.

SERVICE CHANGES

1. Changes on Washer

Item No.	Description	Type 1	Type 2
10	Flat Washer	253182-9	253764-7
12	Flat Washer	253182-9	253765-5
	Serial No.	~ 6809E	6810E ~

Above parts are completely interchangeable as a set.

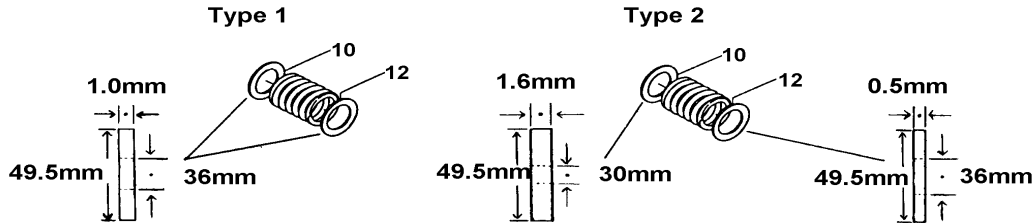

2. Changes on Internal Gear

Item No.	Description	Type 1	Type 2
20	Internal Gear	221242-5 (N/A)	221242-5A
36	Flat Washer 65	-----	253774-4

Above parts are completely interchangeable as a set.

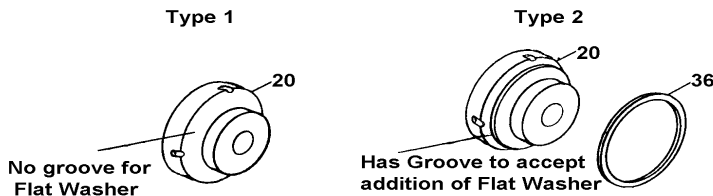

3. Changes on Anvil

Item No.	Description	Type 1	Type 2	Type 3
3	Ring Spring 16	-----	231920-9	231920-9 (component of item no. 6)
6	Anvil / Anvil Assy	325317-3	325586-6	134946-9 (Inc.item no.3)
60	Pin 7	231157-8 (N/L/A)		-----
61	Compression Spring	256710-9		-----
62	Pin 2	256710-9 (N/L/A)		-----
	Serial No.	~ 10254E	~ 10255E - 151572E	151573E ~

Above parts are completely interchangeable as a set.

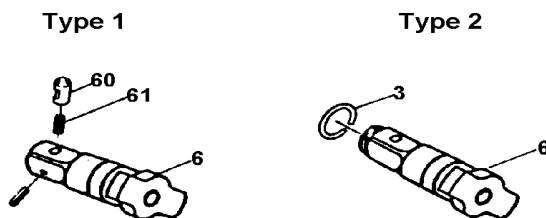

4. Changes on Motor Housing, Handle Cover, Rear Cover, Cord Guard etc.

Item No.	Description	Type 1	Type 2
38	Handle Cover	411213-2 (N/L/A)	414959-9

SERVICE CHANGES

44	Cord Guard	-----	253774-4
50	Motor Housing Com.	156086-3 (N/L/A)	159414-1
53	Rear Cover	284018-1 (N/L/A)	284065-2
54	Screw	911126-2	922221-3
	Serial No.	~ 61130E	61131E ~

Above parts are completely interchangeable as a set.

